

SECTION 9.0 PARKING LOT DESIGN STANDARDS

- 9.1 INTRODUCTION**
- 9.2 PARKING LOT DESIGN**
- 9.3 HANDICAPPED ACCESSIBLE PARKING**
- 9.4 FLEXIBLE PAVEMENT SYSTEM**
- 9.5 SIDEWALKS AND RAMPS**
- 9.6 SHUTTLE BUS STOPS**
- 9.7 SECURITY**
- 9.8 DRAINAGE**
- 9.9 LIGHTING**
- 9.10 STRIPING AND MARKING**
- 9.11 SIGNAGE**
- 9.12 PARKING BARRIERS**
- 9.13 LANDSCAPING**
- 9.14 MAINTENANCE AND REPAIR**
- 9.15 UNFORSEEN CIRCUMSTANCES**
- 9.16 WORKING WITH CAMPUS STAFF**
- 9.17 GLOSSARY**

9.1 INTRODUCTION

These standards are to be used when planning any new or refurbished parking lots on the University of Houston Central Campus. These standards are intended as a guide for the design of these lots and are not intended as a complete set of specifications for their construction.



**FIGURE 1.1
OVERVIEW OF PARKING LOT AND LIGHTING**

9.2 PARKING LOT DESIGN

9.2.1 General

The parking lot design objective is to maximize the total number of parking spaces in the space available with the following considerations:

- The parking layout should provide continuous flow of traffic through the lot.
- The design should allow safe movement of pedestrians from parking to buildings.
- The design should allow for appropriate landscaping of the parking areas without conflicting with site lighting.

9.2.2 Pedestrian and Vehicular Circulation

Circulation patterns shall be as obvious and simple as possible. All likely pedestrian routes should be considered in the design phase to eliminate “short cuts” which will eventually damage landscaped areas.

All site facilities and amenities shall be accessible to people with disabilities in accordance with the provisions of the Architectural Barriers Act – State of Texas and the Texas Accessibility Standards (TAS).

Circulation systems shall be designed to avoid conflicts between vehicular, bicycle, and pedestrian traffic. Pedestrian circulation shall take precedence over vehicular circulation.

Where pedestrian circulation crosses vehicular routes, a crosswalk with yellow striping in plastic paint, speed bumps, or signage shall be provided to emphasize the conflict point and improve its visibility and safety.

Circulation routes shall focus upon main entries and exits and also identify secondary access points.

All elements of the site design shall accommodate access requirements of emergency service vehicles. Currently, there are two primary emergency and service vehicles that require access to the various lots:

- Fire Truck – the pumper truck is 47’ long and 8’ wide. The curb-to-curb turning radius is 40’.
- Tow Trucks – the typical tow truck is 21’ long and 7 ½’ wide. The curb-to-curb turning radius with a car in tow is 47’.

9.2.3 Access to Parking Areas

All off-street parking spaces shall be accessible without backing into or otherwise re-entering a public right-of-way, unless it is physically impossible to provide for such access.

When an off-street parking area does not abut a public street, there shall be provided an access drive not less than 24 feet in width for two-way traffic, connecting the off-street parking area with a public street.

9.2.4 Driveway Design

The location of driveways is based upon many factors, including the location of individual property lines and available street frontage, requirements of internal site design, number of vehicles expected to use the driveways, and traffic safety. Generally, the farther from an intersection a driveway can be located, the less it will affect the through traffic and the less delay it will cause to vehicles using the driveway.

Driveway approaches shall be constructed so as not to interfere with pedestrian crosswalks.

Driveways shall be constructed a minimum of three (3) feet from any obstruction such as a street light or utility pole, fire hydrant, traffic signal controller, telephone junction box, etc.

Driveway entrances shall be designed to accommodate all vehicle types having occasion to enter the lot, including delivery and service vehicles.



**FIGURE 9.2.2
FINISHING CONCRETE AT WHEELER STREET DRIVEWAY**

9.2.5 Parking Lot Layout

Drives that do not allow parking within the driveway right-of-way are 24' for two-way traffic and 12' for one-way traffic. For drives serving thirty (30) or fewer vehicles and where parking is not provided on either side, the width for two-way drives can be reduced to twenty-two (22) feet. Aisle widths are dependent upon traffic flow (one or two-way), angle of parking and whether or not parking is on both sides of the aisle. See Figure 9.2.3 for examples.

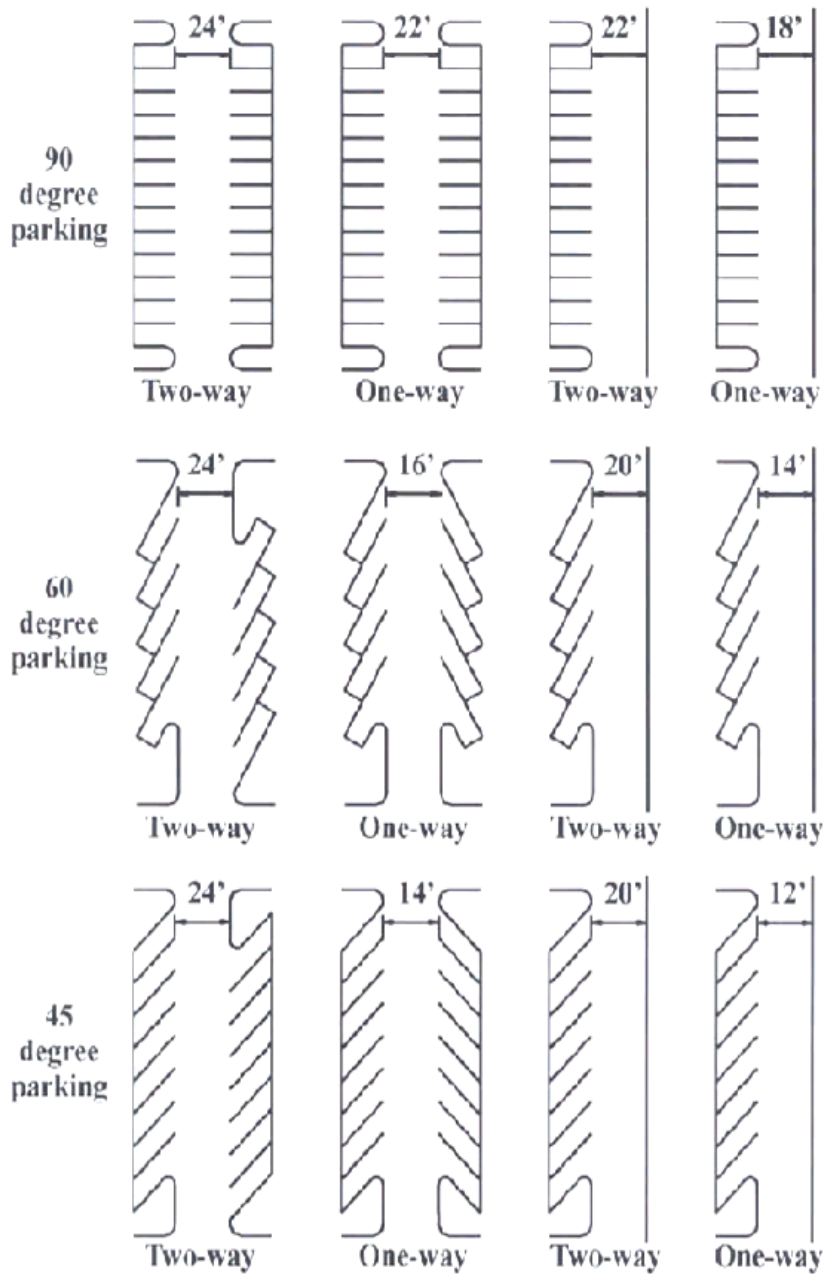

**FIGURE 9.2.3
PARKING LOT AISLE WIDTHS**

9.2.6 Dimensions

All parking spaces, exclusive of access drives or aisles, shall consist of a rectangular area not less than eight and one-half (8½) feet wide by eighteen (18) feet in length except that parallel parking stalls shall be ten (10) feet by twenty (20) feet. For parking dimensions refer to Figure 9.2.4 and Table 2 below:

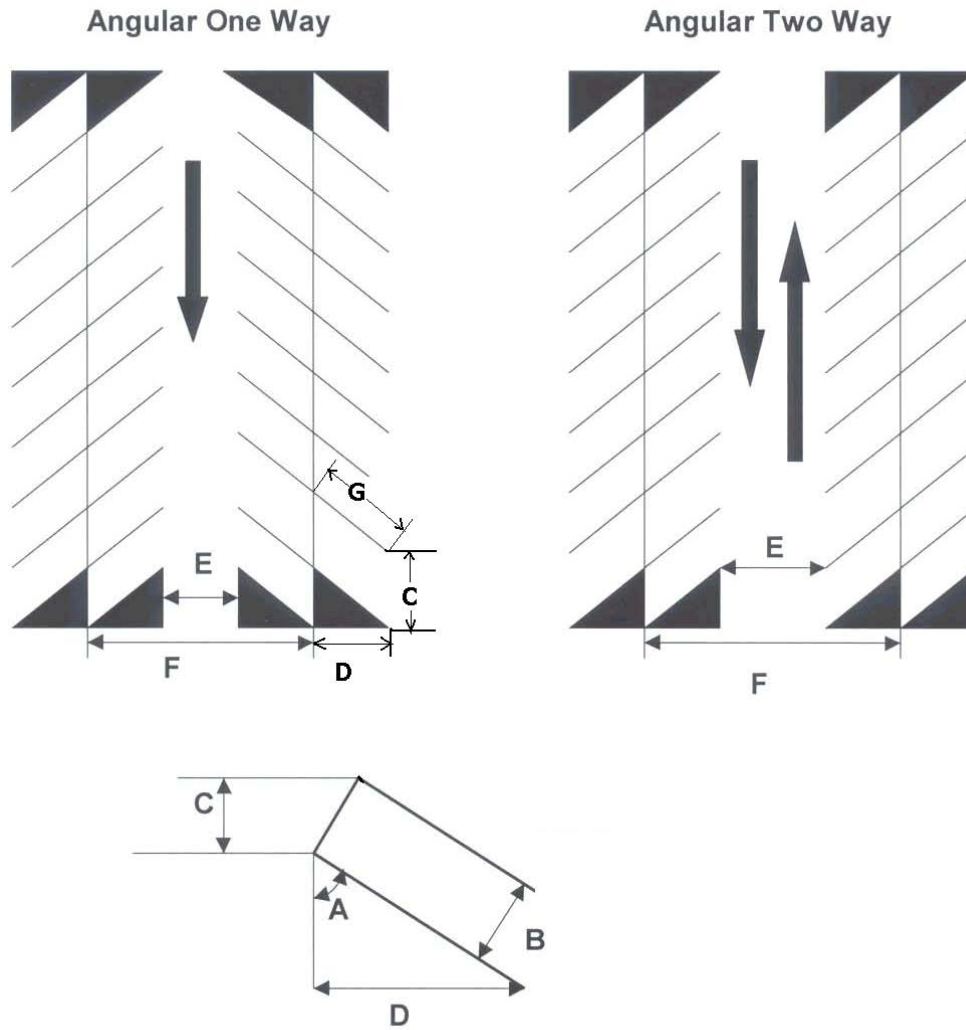

**FIGURE 9.2.4
ACCEPTIBLE PARKING DESIGNS**

| Angle Parking Angle | Dimensions | | | | One Way Traffic | | Two Way Traffic | |
|---------------------------|------------------------|------------------------|------------------------|--------------------------|------------------------|--------------------------|------------------------|--------------------------|
| | Stall Width (ft) | Curb Length (ft) | Stall Depth (ft) | Stripe Length (ft) | Aisle Width (ft) | Section Width (ft) | Aisle Width (ft) | Section Width (ft) |
| A | B | C | D | G | E | F | E | F |
| 30° | 8.5 | 17 | 16.4 | 32.7 | 12 | 44.7 | 24 | 56.7 |
| 45° | 8.5 | 12 | 18.7 | 26.5 | 14 | 51.4 | 24 | 61.4 |
| 60° | 8.5 | 9.8 | 19.8 | 22.9 | 16 | 55.6 | 24 | 63.6 |
| 90° | 8.5 | 8.5 | 18 | 18 | 22 | 58 | 24 | 60 |

**TABLE 2
MINIMAL STANDARDS FOR PARKING ON BOTH SIDES OF AISLE**



**FIGURE 9.2.5
PERPENDICULAR (90°) PARKING SPACES**

The following exceptions to the minimum standards apply:

Spaces Near Obstructions. When the side of a parking space adjoins a wall, column, or other obstruction that is taller than 0.5 feet, the width of the parking space shall be increased by 2 feet on the obstructed side, provided that the increase may be reduced by 3 inches for each 12 inches of unobstructed distance from the edge of a required aisle, measured parallel to the depth of the parking space. (See Figure 9.2.6)

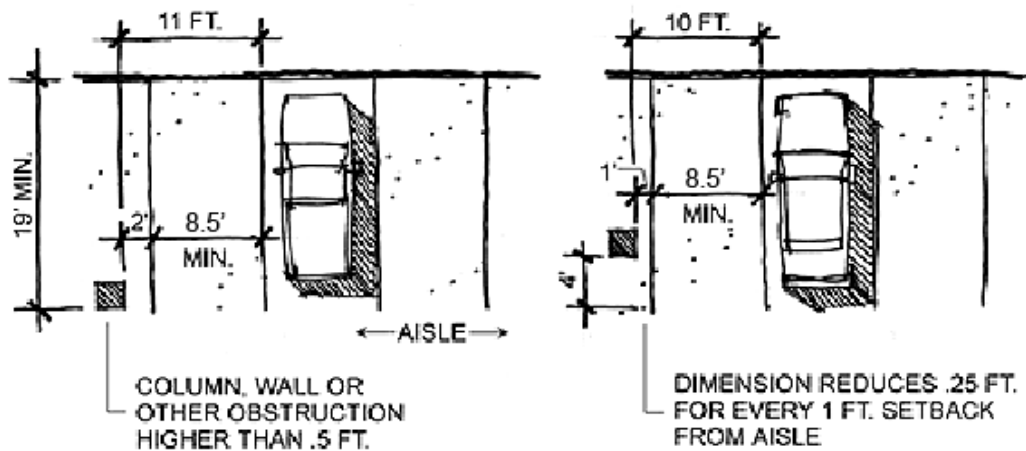

Spaces Near Obstructions

FIGURE 9.2.6

Planter Overhangs. When a parking space abuts a landscape island or planter, the front 2 feet of the required parking space length may overhang the planter, provided that wheel stops or curbing is provided. (See Figure 9.2.7)

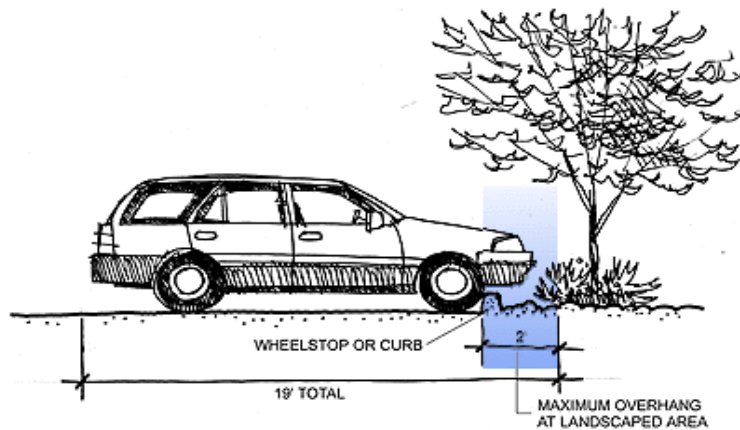

Reduction for Planter Overhangs

FIGURE 9.2.7

9.2.7 Curbs

All new parking lots should be constructed with perimeter curbs wherever feasible. These curbs should be constructed of reinforced concrete and should be either monolithic or lay down depending upon the location and function of the curb. See Figure 9.2.8 for an example of a 6" monolithic concrete curb with gutter.



FIGURE 9.2.8
MONOLITHIC CURB ALONG PERIMETER OF PARKING LOT

9.2.8 Grading

Abrupt or unnatural appearing grading design is not acceptable. Grading on new project sites shall blend with the contours of adjacent properties. Proposed cut and fill slopes shall be rounded off both horizontally and vertically.

When designing a grading plan, balancing the cut and fill is highly encouraged when it does not result in further damage to the natural topography. Where the site plan results in substantial off-haul or infill, a mitigation plan may be required to address the impacts and clean-up of off-site construction activities.

To prevent soil compaction and significant root damage, grading under the drip line of trees is not acceptable.

9.3 HANDICAPPED ACCESSIBLE PARKING

9.3.1 General

Accessible parking for disabled persons must conform to the details and guidelines found in the Architectural Barriers Act – State of Texas and in the Texas Accessibility Standards (TAS).

9.3.2 Accessible Parking Space Location

Accessible parking must be conveniently located near a main accessible building entrance, via the shortest accessible route. For buildings with multiple accessible entrances with adjacent parking, accessible parking spaces should be dispersed and located closest to the accessible entrances.

Accessible parking spaces may be clustered in one or more lots if equivalent or greater accessibility is provided in terms of distance from the accessible entrance, impact of parking fees and convenience.

9.3.3 Route

An accessible route must always be provided from the accessible parking to the accessible entrance. An accessible route never has curbs or stairs, must be at least three (3) feet wide, and has a firm, stable, slip-resistant surface. The slope along the accessible route should not be greater than 1:12 in the direction of travel.

Parked vehicle overhangs shall not reduce the clear width of an accessible route.

9.3.4 Layout

Accessible parking spaces must be 8' wide with a 5' wide adjacent access aisle. The first space and 1 in every 6 additional spaces should be van accessible. Van accessible spaces require an 11' wide space with a 5' wide adjacent access aisle (preferred). Alternatively, van accessible spaces may be 8' wide with an 8' wide access aisle. Two accessible parking spaces may share a common access aisle.



FIGURE 9.3.1
SHARED HANDICAPPED ACCESS AISLES LEADING TO RAMP

9.3.5 Marking and Signage

Signs displaying the international access symbol should be provided at each accessible parking space. The signs should be displayed on fixed mountings in an area where they are not hidden from view. Pavement marking symbols must be used to supplement signs. Spaces intended for van parking should be marked accordingly. Refer to the Americans With Disabilities Act Accessibility Guidelines (ADAAG) for detailed requirements for marking and signs. See Section 9.11 for Sign and Pole details.

“Minimum fine” signage shall be mounted below access symbol signage.



FIGURE 9.3.3
“\$250 MINIMUM FINE” BELOW PARKING SIGN

9.3.6 Number of Spaces

Parking stalls for disabled persons should be provided in each parking lot in accordance with the following table:

| Number of Spaces for Disabled Persons | |
|--|---|
| Total Spaces in Lot | Required Accessible Spaces |
| 1-25 | 1 |
| 26-50 | 2 |
| 51-75 | 3 |
| 76-100 | 4 |
| 101-150 | 5 |
| 151-200 | 6 |
| 201-300 | 7 |
| 301-400 | 8 |
| 401-500 | 9 |
| 501-1000 | 2% |
| 1000+ | 20, plus 1 for each 100, or fraction thereof, over 1000 |

9.3.7 Parking Lot Access Ramps

Ramps must be provided at curbs or other raised barriers to provide access to the accessible routes leading from the parking lot. Ramps must be 48" wide (exceeds 36" code minimum) and ramp grades cannot exceed 1:12. Handrails must conform to the latest requirements in the Architectural Barriers Act.



**FIGURE 9.3.4
ADA RAMP AND HANDRAILS**

9.4 PAVEMENT SYSTEM

9.4.1 General

In recent years the University of Houston has constructed more concrete parking lots than asphalt parking lots. As the construction cost between the two systems diminishes, the University has elected to take advantage of concrete paving's greater durability and lower heat island effect.

Maintenance of existing asphalt lots is predominantly crack repair, seal coating on a regular basis, localized area patches to address potholes and ruts on an as needed basis, and a mid-life asphalt overlay. See 9.14 for further information.

NOTE: Upon completion of all University of Houston asphalt parking lot projects, the contractor is required to submit Material Safety Data Sheets (MSDS) for asphaltic materials used in the project, as well as the amount used (including added kerosene or other cutting agents).

9.4.2 Usage

Since parking lot traffic will consist primarily of passenger vehicles and possibly light construction vehicles from time to time, the Traffic Design Index is DI-1 – Light Traffic (Few vehicles heavier than passenger cars; No regular use by heavily loaded two axle trucks or larger vehicles).

9.4.3 Pavement Standards—Refer to Master Construction Specification Section 32

9.5 SIDEWALKS AND RAMPS

9.5.1 Sidewalks (See also Master Construction Specification 321313 -- CONCRETE PAVING FOR PEDESTRIAN AREAS)

Sidewalks should be constructed according to the following criteria:

Sidewalks shall be 6'-0" wide, 5" thick, with ¼" per foot transverse slope, and shall be reinforced with #3 bar spacing at 14" OC in the interior and #4 bars along the edges. Rebar shall be supported on support chairs. Prior to installing, existing substrate shall be cleaned of all vegetation and proof-rolled. Sidewalk subbase shall be graded using a compacted fine-graded soil with PI of between 13 and 20. Walks designated as traffic-bearing must be at least 6" thick.

The sidewalk should extend above the adjacent finished grade 2".

Sidewalk curves should be formed true and smooth. Contractor should secure approval of formwork from the Project Manager prior to placing concrete for each pour.

New sidewalks should be doweled into existing sidewalks with 12" long smooth No. 4 dowels, with one end greased and thimble, spaced at 12" o.c., with a ½" expansion joint.

Doweled 1" expansion joints in the sidewalk should be located at every 42 feet. Dowels should be 18" long smooth No. 4 dowels, spaced at 12" o.c., with one end greased and thimble.

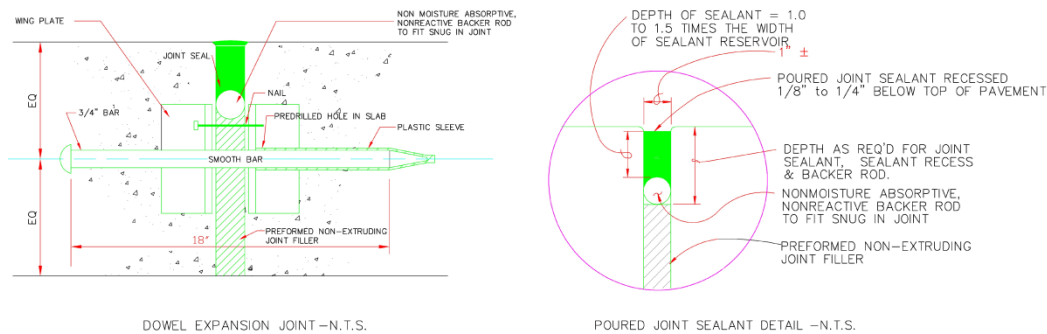

Joint dowel bars for expansion joints should be Grade 60 plain steel bars, as specified under ASTM A615. Cut bars true to length, with the ends square and free of burrs.

The 1" expansion joints for sidewalks should be formed as follows:

- The joint filler should be polyethelene closed-cell expansion joint filler material, Sonoflex F by Sonneborn, or equal.
- Install to a depth of 1" below the walk surface.
- Prior to applying joint sealant, clean the joint and prime joint with primer. Do not prime expansion joint filler material.
- Apply one-component polyurethane self-leveling sealant, conforming to ASTM C920, Type S, Grade P, Class 25, Use T or M, in the upper 1/2" depth of the joint, over the joint filler material.. Alternatively, Install xpansion and Isolation-Joint-Filler Strips: ASTM D 1751, asphalt-saturated cellulosic fiber or ASTM D 1752, cork or self-expanding cork

Control (contraction) joints in the sidewalk should be cut through 1/4 of the slab thickness and have both sides edged and tooled. The layout of the control joints should be indicated in the drawings or described in the project specifications.

All edges and joints should be rounded to a minimum of 1/4" radius with an approved tool. Horizontal surface of edging tool should not exceed 2" in width and should not depress into sidewalk more than 1/16".

All sidewalk surfaces should have a textured, non-slip broom finish free from trowel marks, except for the edging tool. The Contractor should secure approval of walk finish from a UH project representative at the completion of no more than the first 300 sq. ft. of walk construction.

All sidewalks should be cured with liquid-type membrane-forming curing compound complying with ASTM C309, Type I, Class A or B. Curing compound should be applied in strict accordance with manufacturer's recommendations.

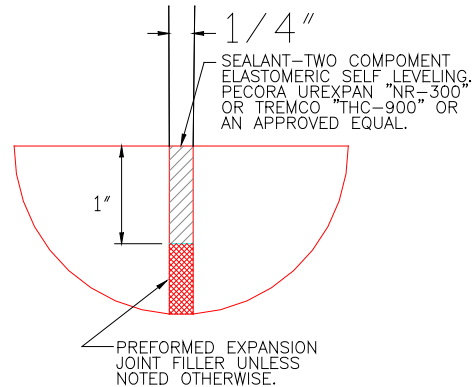

FIGURE 9.5.2
SEALED EDGE ISOLATION JOINT

9.5.2 Accessible Routes

Provide at least one accessible route within the boundary of the parking lot from public transportation stops, handicapped accessible parking and accessible passenger loading zones, and public streets or sidewalks to the accessible building entrance they serve.

Location: Accessible routes shall be located so that pedestrians are not required to wheel or walk behind parked vehicles (except the one they operate or in which they are a passenger) or in traffic lanes.

Width: The minimum clear width of an accessible route shall be 48". If a person in a wheelchair must make a turn around an obstruction, the minimum clear width of the accessible route shall be as shown in Fig. 9.5.3.

Passing Space: If an accessible route has less than 60" clear width, then passing spaces at least 60" by 60" shall be located at reasonable intervals not to exceed 200 ft. A T-intersection of two walkways is an acceptable passing place.

Surface Textures: Ground surfaces along accessible routes including walks, ramps, and curb ramps, shall be stable, firm, and slip-resistant. Sidewalks and walkways should be constructed of concrete or similar materials. Soft or loose materials such as sand, gravel, bark, mulch or wood chips are not suitable.

Slope: An accessible route with a running slope greater than 1:20 is a ramp and shall comply with section 5.4. Nowhere shall the cross slope of an accessible route exceed 1:50.

Change in Levels: Changes in levels along an accessible route up to 1/4" may be vertical and without edge treatment (See Fig. 9.5.4a). Changes in levels between 1/4" and 1/2" shall be beveled with a slope no greater than 1:2 (See Fig. 9.5.4b). If an accessible route has changes in level greater than 1/2", then a curb ramp or a ramp shall be provided that complies with the current Texas Accessibility Standards (TAS). An accessible route does not include stairs, steps, or escalators.

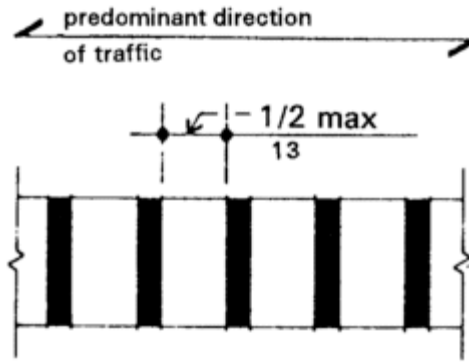

**FIGURE 9.5.5a
GRATINGS**

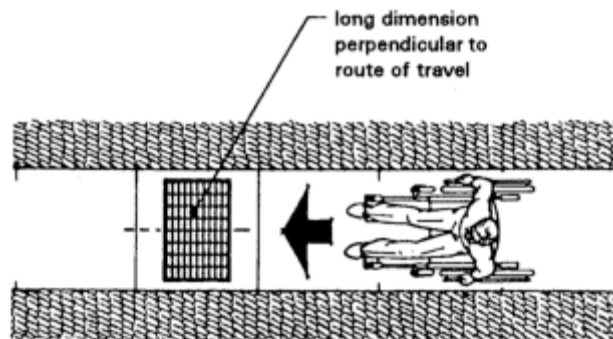
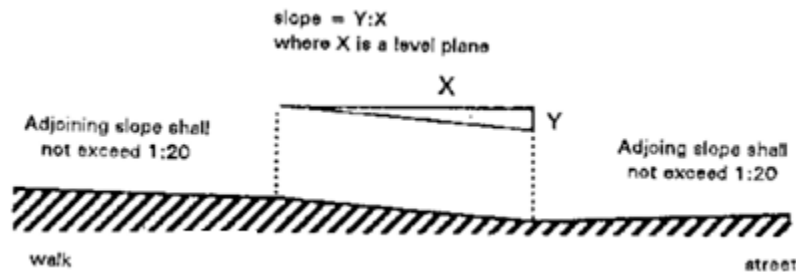

**FIGURE 9.5.5b
GRATING ORIENTATION**

9.5.3 Curb Ramps

Curb ramps must conform to the following standards:

Slope: Slopes of curb ramps shall comply with section 9.5.4. The slope shall be measured as shown in Fig. 9.5.6. Transitions from ramps to walks, gutters, or streets shall be flush and free of abrupt changes. Maximum slopes of adjoining gutters, road surface immediately adjacent to the curb ramp, or accessible route shall not exceed 1:20.

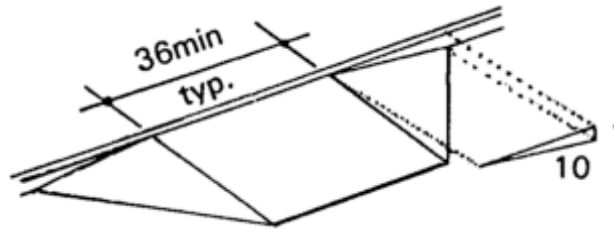

**FIGURE 9.5.6
MEASUREMENT OF CURB RAMP SLOPES**

Width: The minimum width of a curb ramp shall be 36", exclusive of flared sides.

Surface: Surfaces of curb ramps shall be stable, firm and slip-resistant with a broom finish. Transitional textures at base of ramp vary with location. Refer to current TAS 2012 guidelines for current truncated dome requirements.

Built-up Curb Ramps: Built-up curb ramps shall be located so that they do not project into vehicular traffic lanes or into spaces that would interfere with persons entering or exiting parked or standing vehicles (See Fig. 9.5.7).



**FIGURE 9.5.7
BUILT-UP CURB RAMP**

9.5.4 Ramps

Please note that in December 2015, the US Department of Justice released an ADA Compliance Brief affecting handicapped parking striping and parking lot ramp configuration. Please see http://www.ada.gov/restriping_parking/restriping2015.pdf for details.

In accordance with the Texas Architectural Barriers Act any part of an accessible route with a slope greater than 1:20 shall be considered a ramp. Ramps shall be constructed according to the following criteria and shall conform to all current TAS requirements.

Slope and Rise: The least possible slope shall be used for any ramp. The maximum slope of a ramp in new construction shall be 1:12. The maximum rise for any run shall be 30" (See Fig. 9.5.8).

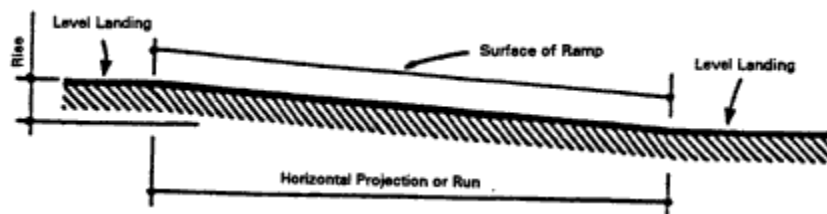

| Slope | Maximum Rise | | Maximum Horizontal Projection | |
|----------------|--------------|-----|-------------------------------|----|
| | in | mm | ft | m |
| 1:12 to < 1:16 | 30 | 760 | 30 | 9 |
| 1:16 to < 1:20 | 30 | 760 | 40 | 12 |

**FIGURE 9.5.8
COMPONENTS OF A SINGLE RAMP
RUN AND SAMPLE RAMP DIMENSIONS**

Clear Width: The minimum clear width of a ramp 30 feet or less in length shall be 44”.

Landings: Ramps shall have level landings at bottom and top of each ramp and each ramp run. Landings shall have the following features:

- It shall be at least as wide as the width of the ramp run leading to it.
- The landing length shall be a minimum of 60” clear.
- If ramps change direction at landings, the minimum landing size shall be 60” by 60”.

Handrails: If a ramp run has a rise greater than 6” or a horizontal projection greater than 72”, then it shall have handrails on both sides. Handrails are not required on curb ramps. Handrails shall have the following features:

- Handrails shall be provided along both sides of ramp segments. The inside handrail on switchback or dogleg ramps shall always be continuous. Ramps in excess of 176” in width shall have intermediate handrails spaced a maximum of 176” on center.
- If handrails are not continuous, they shall extend at least 12” beyond the top and bottom of the ramp segment and shall be parallel with the floor or ground surface (See Fig. 9.5.7).
- The *nominal* diameter or width of the gripping surfaces of a handrail shall be 1-1/2”, or the shape shall provide an equivalent gripping surface.
- If handrails are mounted adjacent to a wall, the space between the wall and the handrail shall be 1-1/2”. Handrails may be located in a recess if the recess is a maximum of 3” deep and extends at least 18” above the top of the rail.
- Handrails shall be of low maintenance materials such as galvanized metal or factory finished aluminum; or shall be painted with epoxy paint. Typical handrail color is black.

Cross Slope and Surfaces: The cross slope of ramp surfaces shall be no greater than 1:50. Ramp surfaces shall comply with Section 9.5.2.

Edge Protection: Ramps and landings with drop-offs shall have curbs, walls, railings, or projecting surfaces that prevent people from slipping off the ramp. Curbs shall be a minimum of 2” high.

Outdoor Conditions: Ramps approaches shall be designed so that water will not accumulate on walking surfaces.

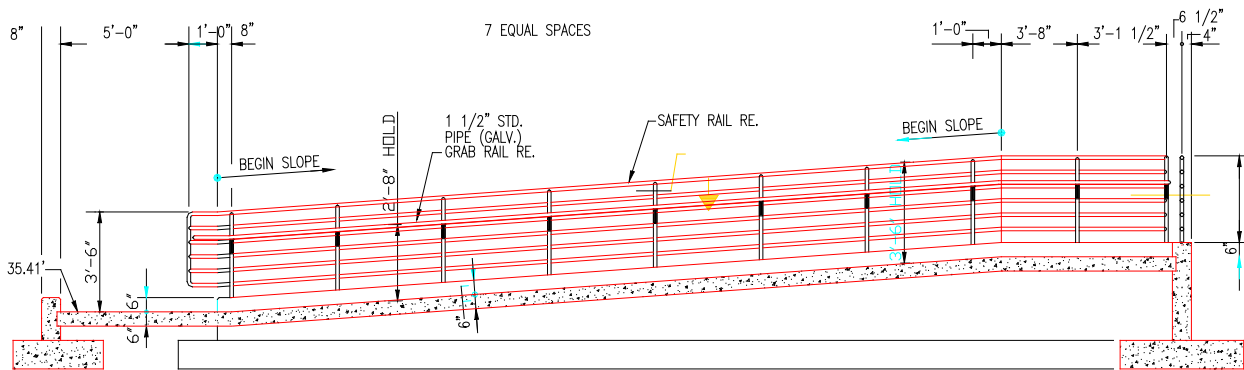

FIGURE 9.5.9
ADA RAMP AND HANDRAILS

9.6 SHUTTLE BUS STOPS

9.6.1 General

The University of Houston will designate locations for Shuttle Bus Stops requiring a concrete slab for a shelter. These locations will be clearly drawn on the parking lot construction drawings.

9.6.2 Criteria

Shuttle Bus Shelter pads will be constructed of 6" poured concrete (3500 psi) 18' x 24' in size unless otherwise shown on the individual shelter plans. Concrete slabs will be reinforced with #3 bar spaced a maximum of 18" apart in both directions. Concrete surface shall be broom finished and feature 2% slope to rear of pad for drainage.

Where Shuttle Bus Shelter pads are above pavement height, a curb ramp conforming to Section 5.3 will be constructed to allow handicapped access to or from the pad.

9.7 SECURITY

9.7.1 General

Each parking lot presents its own particular problems based on physical layout, terrain, and security requirements. Campus parking lot security can be enhanced through a combination of lighting, surveillance and response. These actions will improve security, deter crime, reduce potential liability and make staff and students feel safer.



**FIGURE 9.6.1
FRAMING AND REINFORCING FOR CONCRETE PAD**

9.7.2 Security Lighting (see also SECTION 11.0 --LIGHTING DESIGN GUIDELINES)

Security lighting is used to increase effectiveness of campus police forces by increasing the visual range of the police during periods of darkness or by increased illumination of an area where natural light does not reach or is insufficient. Lighting also has value as a deterrent to potential individuals looking for an opportunity to commit crime. Normally security lighting requires less intensity than working areas. Police must be able to identify badges, people at gates, observe activity, inspect vehicles, observe illegal entry attempts, detect intruders in the protected area, and observe unusual or suspicious circumstances. The goal of direct illumination is to provide the specified intensity throughout the area for support of campus police, provide good visibility for faculty, students or staff and have a minimum of glare. Lighting must follow the provisions of Section 9 of this manual.

As a rule of thumb, illumination levels at entrances, exits, loading zones and collector lanes of parking areas should not be less than twice the illumination of the adjacent parking area or the adjoining street whichever is greater.

9.7.3 Layout

Normally students and staff who arrive early also leave early, leaving late arrivals the less secure (further away from buildings and traffic flow) parking spaces. Since these late arrivals also are usually the last to leave, they are also the most vulnerable to crime. By rerouting incoming and outgoing traffic through the parking lot to pass by the more remote areas, natural surveillance is increased and criminal opportunity is reduced.

Parking perpendicular to the line of sight reduces the criminal value of hiding between cars waiting for potential victims. Walking corridors between cars at strategic locations also concentrates foot traffic and increases natural surveillance by students and staff.

9.7.4 Emergency Call Stations

Surveillance without potential response provides little increase in system trust by customers. Emergency Call Stations that can be used to call security forces or police to an emergency situation should be provided at multiple convenient locations in each lot. Availability of these call stations for use by customers observing a crime in progress or by victims who are threatened provides a considerable increase in comfort level for staff and students. These systems provide immediate voice contact (with security forces), alarm (to attract attention) and light signal (quick location of trouble spot).

The UH emergency call station system consists of a one button hands-free direct dial communications unit. There are two different types of units one for wall mounting and one standalone exterior mounting. The communications units are manufactured by Code Blue (www.codeblue.com). For current specifications, please see Master Construction Specification Section 28 26 00 - Electronic Personal Protection Systems.



**FIGURE 9.7.1
CODE BLUE EMERGENCY
CALL BOX**

9.7.5 Barrier Gates

Barrier gates are a means of restricting use of parking spaces to those individuals with pre-approved permission to park in a specific lot. Gates can be a two-way gate system or a single card gate with a separate controlled egress. (See Figures 9.7.2 and 9.7.3)



**FIGURE 9.7.2
BARRIER GATE**

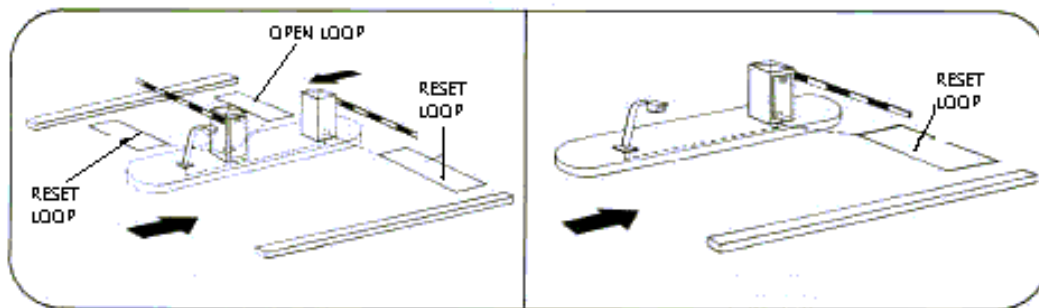

a. Two Way Gate System

b. Card Gate

**FIGURE 9.7.3
PARKING LOT GATE SYSTEMS**

9.8. DRAINAGE

9.8.1 General

All parking lots shall be designed to develop proper site drainage, directed at the disposal of all storm water accumulated on the site. Parking lots constructed on UH campuses and other facility sites which contain an area of 2,500 square feet or more; and which are located within 150 feet of an existing storm sewer or other drainage way, including an open channel or creek, should be designed to direct storm water runoff into such storm sewers or drainage ways. The parking lot should be graded and surfaced such that storm water runoff from the site is collected on the site

by a parking lot drainage system and carried to the storm sewer system, and not allowed to discharge through the driveway entrances and exits onto the public way. Proposed finished elevations of the parking lot must be indicated on appropriate plans. The site drainage design must not restrict flows that could occur during a 100-year flood condition.

9.8.2 Proper Drainage

Laboratory testing and practical experience have demonstrated the dramatic reduction in the ability of a soil to resist stresses in the presence of excess moisture. For this reason, one of the most important functions of a pavement is to provide a seal over the underlying soil or sub grade.

Although the pavement itself absorbs much of the traffic-induced stress, invariably some of this pressure is ultimately transmitted to the soil foundation. If there is excess moisture in this soil, it may be unable to resist the applied loads. The load will eventually exceed that which the pavement can tolerate, and a local failure will result.

Excess moisture can be prevented by proper drainage. Properly designed inlets and culverts should efficiently remove storm water from the parking lot surface. Where necessary, subsurface drains should be used to collect and dispose of groundwater before it can reach the sub grade.

Evidence of poor drainage, which includes ponding (bird baths) or standing water that does drain from the surface of a parking lot, is an unacceptable consequence of poor parking lot construction. The University of Houston will require that the paving contractor rectify any ponding susceptible areas at their cost and at a schedule and method acceptable to the University during the first year following handover of the parking lot to the University.

9.8.3 Pipes

Refer to Master Construction Specification Division 33. All drainage pipes shall be constructed of Reinforced Concrete Pipe (RCP). Pipes shall be designed for free flow and a minimum velocity of 3.0 fps at peak design flow. Wherever possible underground utilities should parallel the roadway centerline.

9.8.4 Storm Drain Manholes, Junction Boxes and Cleanouts

Manholes are required at:

- Any change in horizontal or vertical alignment of underground drainage pipe. Minor horizontal curvature in pipe less than 15 degrees may be allowed, (without manholes or cleanouts), depending on pipe size, street alignment, degree of curvature and reason. Maximum joint deflection shall be per manufacturer's recommendation.
- All connections.
- All changes in pipe size.
- At least every 500 feet.

Standard catch basins, junction boxes, or cleanouts may be used in place of manholes for pipe no larger than 18 inches in diameter and with a depth less than 4.0 feet.

Avoid placing manholes within a parking space. Wherever possible manholes should be located behind the curb or in drive lane.

9.8.5 Inlets and Catch Basins

Inlets and catch basins are required at:

- All low spots and shall be connected to a storm drainage facility.
- At least every 500 feet of gutter length.



**FIGURE 9.8.2
MONOLITHIC CURB, INLET AND CATCH BASIN**

9.8.6 Open Channels

All existing ditches and other open channels feeding a pipe with a diameter greater than 36 inches shall remain open channel except at road crossings.

Where possible, ditches shall be located along or adjacent to lot lines.

For reasons of maintenance and safety, bank slopes shall be 4:1 or flatter.

The maximum allowable design velocity is 7 fps.

The minimum allowable design velocity is 2 fps. The installation of a concrete lined low-flow channel may be required to achieve minimum velocity.

The normal maximum depth for an open ditch is 4 feet outside of road rights-of-way and 2 feet adjacent to the roadways.

9.9 LIGHTING (see also SECTION 11.0 --LIGHTING DESIGN GUIDELINES)

9.9.1 Purpose

Parking lot lighting is vital for traffic safety; for protection against assault, theft and vandalism; for convenience; and for comfort to the user. Lighting on parking lots at the University of Houston Central Campus are to be designed to provide the minimum lighting necessary to ensure adequate vision and comfort while being arranged so as not to cause visual interference on public thoroughfares or encroach on the visual privacy of adjacent building occupants.

9.9.2 Criteria

Lighting systems are to be designed to conform with Illuminating Engineering Society of North America (IESNA) requirements, to the International Dark-Sky Association (IDA) recommendations, and to the following criteria:

General: All UH parking lot lighting will utilize a standard luminaire and pole height unless the Director of Facilities Planning and Construction directs otherwise.

Illumination Level within the Parking Lots: Illumination levels at any point across the parking lot must not be greater than 6.0 foot-candles in the horizontal plane, and must not exceed 0.5 vertical foot-candles. All points across the interior of the parking lot must have an illumination level greater than 3.0 foot-candles. Illumination in low traffic areas must not fall below the 2.5 foot-candles level.

Illumination Level Beyond Parking Lot Perimeter: Illumination attributable to a parking lot lighting system should not exceed 0.50 horizontal foot-candles beyond the perimeter of the parking lot.

Illumination Level at High Traffic Areas: Illumination levels at entrances, exits, loading zones and collector lanes of parking areas should be greater than twice the illumination of the adjacent parking area or the adjoining street, whichever is greater.

Uniformity Ratio: The illumination uniformity ratio should not exceed 3:1, average to minimum, or 4:1 maximum to minimum. The use of unnecessarily high wattage lights can actually lead to a less secure environment by creating dark pockets just outside the range of the lights.

Glare Control: Lighting should be designed to protect against glare onto public rights-of-way that could impair the vision of motorists and adversely impact adjoining properties. Lighting adjacent to buildings and/or residential districts must be arranged so that the luminaires have a sharp cutoff at no greater than 78 degrees vertical angle above nadir. Not more than five (5) percent of the total lamp lumens can project above 78 degrees vertical.

Spillover: In the ideal case, all exterior light would be shielded from adjacent properties by existing vegetation, thick evergreen vegetated buffers, berms, walls or fences, and/or the use of directional lighting, lighting shields, special fixtures, timing devices, appropriate light densities, luminaires, and mountings at established heights. A design objective for all UH parking lots is for outdoor lighting to be designed and located such that the maximum illumination measured in foot-candles at the property line shall not exceed 0.5 onto adjacent residential sites and 1.0 onto adjacent commercial sites and public rights-of-way.

Orientation: The intent of UH parking lot lighting is to minimize or eliminate light directed upward. Light emitted at angles of 80 degrees higher (where straight down is 0 degrees) fails to produce useful illumination on horizontal surfaces in open areas. At these high angles light produces significant glare, light pollution, and energy waste. Light above 90 degrees is totally wasted and produces undesirable sky glow.

Placement: The placement of light poles within raised curb planter areas is encouraged, but conflicts with parking lot trees, which can obscure the lighting, should be avoided. The distance separating lights will be determined by the geometry of the parking lot and the requirement to satisfy illumination levels.

Control: Lighting must be designed to interface with the existing University control system where lighting is currently controlled by photocells. Each lighting circuit must be equipped with a manual over-ride switch. Lighting should be capable of bi-level control within a future campus-wide energy management system.

9.9.3 Luminaires

Parking lot illumination at the University of Houston is in a transitional phase between the traditional metal halide fixtures and preferred LED lighting. It is anticipated that a LED retrofit fixture adaptable to the current luminaire standard soon can be found and implemented in its place.

Mounting Height: The mounting height is measured from the finished grade or surface and includes the total height of the luminaire, pole, and any base or other supporting structure required to mount the light. Parking lot luminaires shall be designed, located and mounted at heights no greater than:

- 33-feet above grade for cutoff lights (See Figure 9.9.1)

Pole bases: Raised light pole bases shall be attractively designed and compatible with the overall campus. The standard is a 2 ft. diameter, cylindrical concrete base set 8.0 ft. below and 2.5 ft. above grade. The top of the base must be finished in a slight convex shape to prevent water pooling at the base of the light pole. (See Figure 9.9.3 for details).

Light Source: Lamps shall be metal halide (MH), 20,000 hour type. Lamps for cut-off luminaires shall not exceed 400 watts without specific approval of the University of Houston.

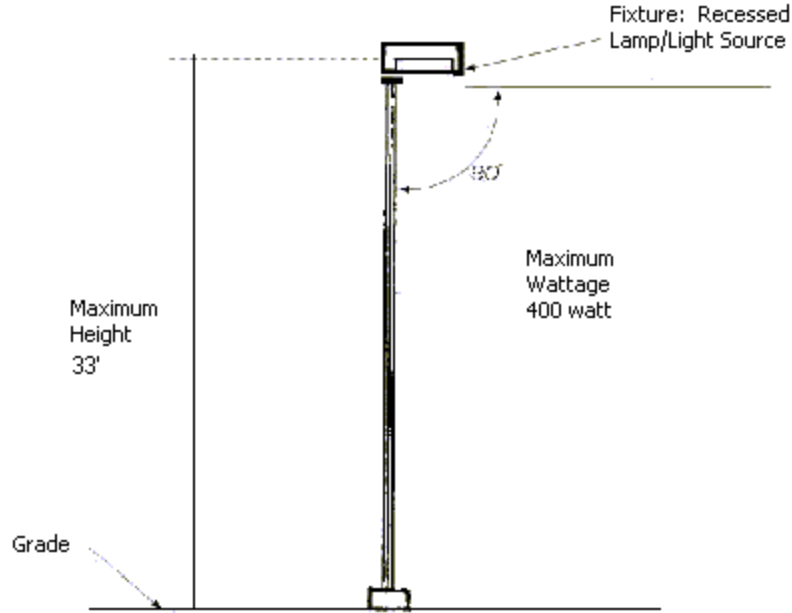

**FIGURE 9.9.1
CUTOFF LIGHT FIXTURE**

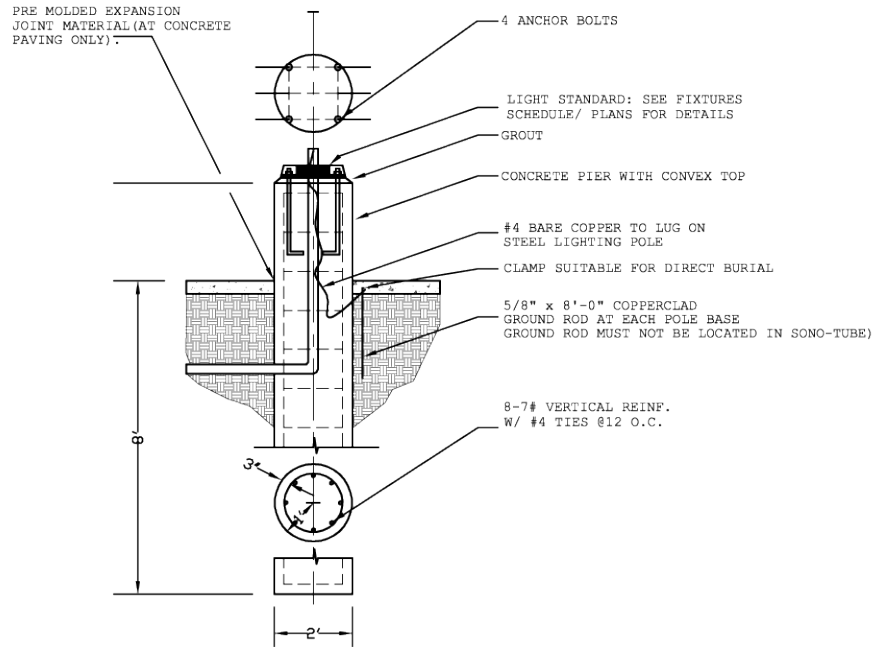

**FIGURE 9.9.3
LIGHT STANDARD POLE BASE**



FIGURE 9.9.4
REBAR, ELECTRICAL CONDUIT



FIGURE 9.9.5
CONCRETE LIGHT POLE BASE WITH ANCHOR BOLTS

9.9.4 Luminaire Specifications

All luminaires will have to meet the provisions of the International Dark-Skies Association. The current UH standard luminaire is:

Single Head: Lithonia Lighting model: KVR2 400M ASYC RPVD12 DBL or approved equal
Double Head: Lithonia Lighting model: KVR2 400M SYMC RPVD12 DBL or approved equal

Alternative luminaries must be approved by the University and must meet the following specifications:

Housing: Parking lot pole mounted fixtures are to be cylindrically shaped and constructed of 0.90 heavy gauge spun aluminum. The internal components of the fixture must be accessible through the top of the fixture. Access to the ballast should not require the removal of the internal reflector. EPA shall be 1.5 ft squared.

Lens: Each fixture must have impact-resistant, clear, 3/16-inch thick tempered glass drop lens.

Fixture Style: Fixtures can be either double head or single head depending upon the location of the assembly and the illumination required. Note that shielding may be required at the fixture to prevent light spillover and glare when the luminaire is set adjacent to a residential area.

Optics: The fixture must have segmented, anodized aluminum optics, field interchangeable and rotatable. Fixture shall be vertically lamped with sealed optical chamber. Optical design shall redirect light around the arc-tube for optimum lamp life and fixture efficiency.

Electrical System: Fixture must be 480V 1phase 60 cycle, constant-wattage autotransformer, high-power factor ballast. Ballast is copper wound and must be 100% factory tested. The assembly should include a removable power tray and positive locking disconnect plug. Lighting should be capable of bi-level control and should be pre-wired for a future campus-wide energy management system. Double head fixtures must be 480V 3 phase 60 cycle to balance loads.

Finish: The polyester paint finish must meet or exceed the following paint standards:

- ADHESION: ATSM D 3359
- IMPACT: ATSM D 2794
- FLEXIBILITY: ATSM D 522 (1/8' CONICAL MANDREL)
- SALT SPRAY: ATSM B 117, D 1654
- HUMIDITY: ATSM D 2247, D 1654

9.9.5 Pole Requirements

The current UH standard light pole for parking lots is:

Single Head: Valmont model: DS210 800A300 DM10 FP FBC or approved equal
Double Head: Valmont model: DS210 800A300 DM2180 FP FBC or approved equal

Alternative poles must be approved by the University and should meet the following requirements:

Anchor Bolts: Anchor bolts should be fabricated from carbon steel bar conforming to AASHTO M314 Grade-55 or ASTM F1554 Grade-55. Bolts should have an “L” bend on one end and be galvanized a minimum of 12” on the threaded end. Four anchor bolts are required per pole. Each anchor bolt must be furnished with two hex nuts and two flat washers that meet the same requirements as anchor bolts.

Anchor Base: The anchor base (base plate) shall be fabricated from structural quality hot rolled carbon steel plate conforming to ASTM A36. The base plate shall telescope the pole shaft and be circumferentially welded on top and bottom.

Pole Shaft: The pole shaft shall conform to ASTM A595 Grade-A and shall be 11-gauge thick. The pole must be of single piece construction, with a full-length longitudinal high frequency electric resistance weld. The pole shaft is to be round in cross-section and have a uniform taper of approximately 0.14 inches per foot of length.

Hand Hole: A 4” x 6.5” hand hole is to be located 1’-6” above the pole base plate. The hand hole is to be provided with a steel attachment bar, and a steel cover with hex head stainless attachment screws.

Pole Coating: Pole coating shall be a black, powder finish coat.

Surface preparation: Exterior pole surfaces must be blast cleaned to Steel Structures Painting Council Surface Preparation Specification No. 6 (SSPC-SP6) requirements utilizing cast steel abrasives conforming to Society of Automotive Engineers (SAE) Recommended Practice J827.

Interior Coating: Interior pole shaft surfaces shall be mechanically cleaned and coated at the base end for a length of approximately 2.0’ with a zinc rich epoxy powder. The coating shall be electrostatically applied and cured in a gas fired convection oven by heating the steel substrate to a minimum of 350 degrees and a maximum of 400 degrees F.

Exterior Coating: All exterior surfaces shall be coated with either Urethane or Triglycidyl Isocyanurate (TGIC) Polyester Powder to a minimum dry film thickness of 2.0 mils for Urethane Powder and 3.0 mils for TGIC Powder. The coating shall be electrostatically applied and cured in a gas fired convection oven by heating the steel substrate to a minimum of 350 degrees and a maximum of 400 degrees F.

9.9.6 Maintenance

The current UH standard luminaire and pole selections are designed to accommodate maintenance accessibility, with long ballast and lamp lives, and to resist dirt, animal droppings, bird nests, vandalism, and water damage.

Note that outdoor lighting fixtures require regular maintenance. Lamps tend to produce less light as they age and should be replaced at scheduled intervals and not just when they burn out. Dirty light fixtures also produce less light. Arrange to have the luminaires cleaned both inside and outside on a regular basis.

The growth of trees and other types of landscaping can have a significant effect on outdoor lighting. Even a well-designed lighting system can become ineffective as trees grow to a point

where they block out large portions of the light. Arrange to have trees and landscaping regularly trimmed so that the lighting system is not adversely affected.

9.10 MARKING AND STRIPING

9.10.1 Layout

The project design drawings must include a detailed and accurately scaled parking lot layout clearly showing the location of parking spaces and aisles. The dimensions of the parking spaces, aisles and driveways must conform to the layout design standards included in this guideline.

9.10.2 Marking

The construction documents should require the parking spaces to be marked on the parking lot surface according to layout shown on the project design drawings, and should conform to the following criteria:

Each required parking space shall be identified by surface markings and shall be maintained in a manner so as to be readily visible and accessible at all times. Such markings shall be arranged to provide for orderly and safe loading, unloading, parking and storage of vehicles.

One-way and two-way access into parking facilities shall be identified by directional arrows. Any two-way access located at any angle other than 90 degrees to a street shall be marked with a traffic separation stripe the length of the access. This requirement does not apply to aisles.

Markings that are required to be maintained in a highly visible condition include striping, directional arrows, lettering on signs, lettering in handicapped-designated areas, and field color.



**FIGURE 9.10.1
ACCESSIBLE SPACE MARKING**

Each loading space shall be striped or permanently designated by other suitable methods and permanently posted with a sign restricting its use to loading.

Parking spaces shall be permanently marked with striping in accordance with all federal, state and local standards. As a minimum lines, shall be located along the sides and, unless curbing is present, at the head of parking stalls. Lines shall be four (4) inches wide and should extend the full length of the space.

“YIELD” markings shall be painted in yellow letters a minimum of 36” high at the end of each parking row as it intersects either a drive lane or another parking row that has priority flow for traffic.



**FIGURE 9.10.2
YIELD MARKINGS AND YELLOW STRIPING**

9.10.3 Striping

Please note that in December 2015, the US Department of Justice released an ADA Compliance Brief affecting handicapped parking striping and parking lot ramp configuration. Please see http://www.ada.gov/restriping_parking/restriping2015.pdf for details.

Striping shall be one consistent color, semi-permanent, reflective traffic paint with reflective glass beads to enhance visibility. See Master Construction Specification Division 32 Exterior Improvements for paint specifications.

Parking spaces will be striped white except at the end of each row of parking or at handicapped accessible aisles. These lines will be painted yellow. All cross walks, no parking areas and access walks will be striped in yellow.

Parking spaces are a minimum of 8' 6" wide from center of stripe to center of stripe. All lines must be 4" wide.



**FIGURE 9.10.3
STRIPING**

9.10.4 Re-striping

When an existing parking lot is re-stripped, the re-striping must provide accessible parking spaces as required by the ADA Standards for Accessible Design and the Texas Accessibility Standards (TAS). These requirements are outlined in Section 3 and Section 5 of this Manual.

9.11 SIGNAGE

9.11.1 General

Parking, handicap, and other signage must conform to the U.S. Department of Transportation *Manual on Uniform Traffic Control Devices Standard* and the Americans with Disabilities Act standards. All signs must meet University of Houston standards for colors and lettering.

9.11.2 Sign Size

All signs must have a ratio that is neither greater than 3.20 nor less than 1.75 (ratio: divide the length by the height).

Street signs and standard roadway signs will be 18" wide by 24" high. Examples include "Do Not Enter" and "One Way" (without arrow). See Figure 9.11.1.

Handicap (ADA) and other parking signs will be 12" wide by 18" high. See Figures 9.11.2 and 9.11.3

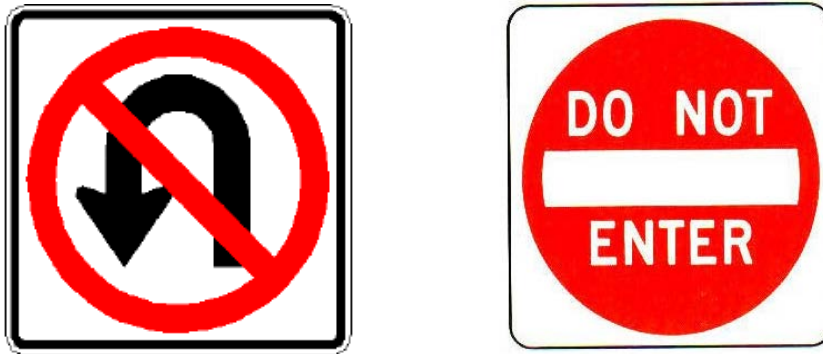

**FIGURE 9.11.1
STANDARD STREET AND ROADWAY SIGNS (18"×24")**



| Colors |
|---------------------------------|
| Legend and Border -- Green |
| White symbol on Blue background |
| Background – White |

**FIGURE 9.11.2
ACCESSIBLE PARKING SPACE SIGN (12"×18")**

9.11.3 Font Size

Font size is strictly dependent on the nature of the sign; i.e. whether the sign is intended for vehicular or pedestrian traffic. Only the rules that apply to traffic around the University are detailed in Figure 9.11.3.

| Travel Speed | Traffic Category | Reading Distance | Appropriate Letter Height | Appropriate Symbol Size |
|---------------------|--|-------------------------|----------------------------------|--------------------------------|
| 0 mph | on campus pedestrians | 5 feet | 1 inch | 4 inches |
| 0-10 mph | pedestrians cyclists rollerbladers | 10 feet | 2 inches | 8 inches |
| 10-40 mph | Vehicular | 20 feet | 4 inches | 16 inches |

FIGURE 9.11.3 SIZES FOR CAMPUS SIGNAGE

9.11.4 Sign Materials

Sign materials depend upon the following criteria:

- DOT standards include 0.080 gauge aluminum signs covered with Approved Engineer Grade (SEG) reflective sheeting for street and parking signs.
- ADA standards include a 6" pictogram with verbal description, 1/32" raised letters and numerals, 5/8" minimum letter height, raised grade 2 Braille, and 70 percent contrast between background and text for all handicap signage.
- All other signs can be made from metal or Dura-ply.

9.11.5 Pole/Mounting Post

Poles shall be manufactured or constructed of 2" O.D. round galvanized pipe. Poles for street signs or standard roadway signs should extend 9' 0" above the parking surface. Poles for Handicap markings should be 6' above the pavement. All poles must be set in concrete footings extending a minimum of 2' 6" below the surface. Signs should be mounted as close to the top of the post as possible. See Figure 9.11.4 for details.

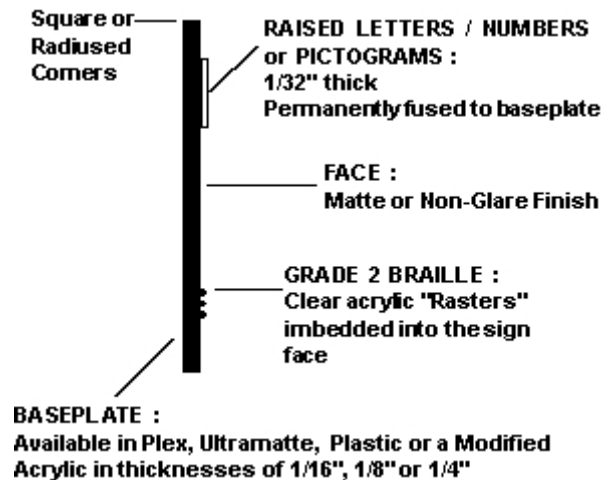

FIGURE 9.11.4
STANDARD POLE DETAILS



**FIGURE 9.11.5
ACCESSIBLE PARKING SIGN WITH FINE**

9.11.6 Quality Assurance

Manufacturer should have a minimum of 5 years experience in manufacturing signage. All signage is to be manufactured by one manufacturer. Install traffic signs in accordance with the manufacturer's written installation instructions and the project plans.

9.11.7 Replacement

All signs should be replaced on an as-needed basis to reflect the proper image of the University.

9.12 PARKING BARRIERS

9.12.1 Purpose

All parking areas and spaces shall be provided with bumper barriers, wheel stops, or wheel stop curbing designed to prevent parked vehicles from extending beyond the property lines, damaging adjacent landscaping, walls or buildings, or overhanging sidewalk areas. Each handicapped accessible parking space without a curb stop should be furnished with a parking barrier. Barriers should not block the access aisles between handicapped accessible spaces.

9.12.2 Approved Barriers (Wheel Stops)

Prefabricated concrete parking barriers, where used, shall be a minimum of 6" wide, 6" high, and 6 feet long (See Figure 9.12.1). Prefab barriers must be firmly and permanently anchored a minimum of 12" below the pavement with galvanized anchor pins (See Figure 9.12.2).

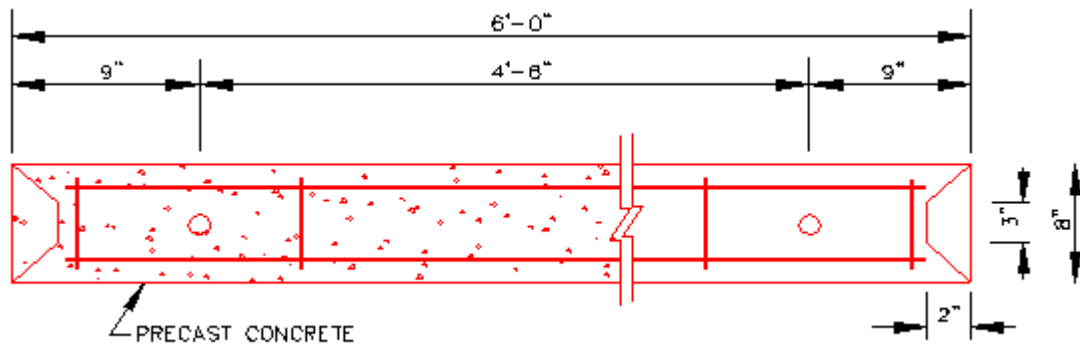

FIGURE 9.12.1
PRE-CAST CONCRETE PARKING BARRIER

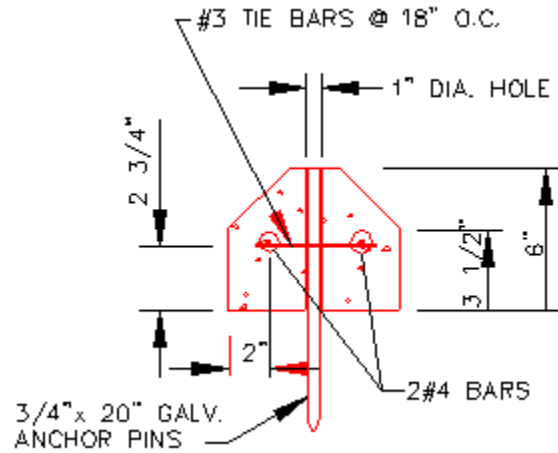

FIGURE 9.12.2
PARKING BARRIER ANCHORS

9.12.3 Location

Barriers should be located to contain the parking within the approved parking lot. When a concrete curb is used as a barrier for perpendicular or angle parking, it should be offset at least two (2) feet from the edge of the parking lot to allow for the front overhang of the vehicle.

9.12.4 Painting/Marking

All parking barriers (wheel stops) will be painted white except for the following:

- Yellow – No Parking / Tow Away Zones
- Red – Emergency Vehicle / Fire Zones

- Blue – Handicapped Parking
- Black Letters – Denote Reserved Spaces (usually with a space number)

9.12.5 Benefits

Properly placed barriers protect structures and landscaping from vehicle damage.

Bumpers encourage drivers to pull all the way into a parking space. This ensures adequate clearance behind the vehicle for other traffic.

Bumpers along a centerline of a double row of parking can prevent drivers from taking unsafe short cuts through a parking lot.

9.13 LANDSCAPING OF PARKING AREAS

9.13.1 General

The requirements described under this section include the minimum provisions prescribed in the City of Houston Code of Ordinances, Chapter 33: Planning and Development, Article V: Trees, Shrubs and Screening Fences. The intent of these guidelines is to establish standard criteria for landscape design of all new and/or renovated surface lot parking areas.

9.13.2 Existing Condition

The vast majority of campus parking consists of large expansive lots situated along the perimeter of campus. Many of the lots have been screened with continuous rows of shrub hedges and trees. There are little or no landscape treatments in the interior of the lots.

9.13.3 General Guideline

Vehicular parking areas shall be both functionally and aesthetically pleasing. The overall goals of implementing these requirements are to enhance, beautify, provide aesthetic unity with the rest of the campus environment, improve the environmental and climatic impact of surface parking lots and to minimize the vast, barren character of existing and future parking areas while providing efficient parking, vehicular circulation and safe pedestrian access. Large canopy trees shall dominate the parking areas for shade and shrubs along the perimeter shall be provided for screening.

The University will implement a sequence for phasing in renovation of existing parking lots that contain little or no landscaping to meet the requirements of this section. This sequence is not a timetable and implementation will occur as funding becomes available. First priority will be given to Campus Core lots and/or other high profile lots, with the renovations moving out to the large, outlying lots on the edge of Campus.

9.13.4 Numerical Requirements

The parking lot design shall include one (1) tree for every ten (10) parking spaces, rounding up or down in the case of a fraction to the nearest whole number, and in no case shall be less than one

(1) tree. Required trees must be located in the interior of, or an area adjacent to the parking lot. For parking lots with more than 20 parking spaces, a minimum of five percent (5%) of the total interior parking lot area shall be landscaped (excluding perimeter landscaping).

In addition to the parking lot tree requirements described above, shrubs shall be planted along the perimeter of all parking surfaces so that the parking lot is screened from all adjacent public streets, exclusive of driveway entrances, pedestrian walkways and visibility triangles. Shrubs shall be maintained at a height of no more than 36 inches nor less than 18 inches as measured from the surrounding soil line. The number of shrubs required shall be equal to the total number of street trees required multiplied by ten (10). No less than 75 percent of the shrubs required under this section shall be planted along the perimeter of the parking surface adjacent to the public street. A minimum 10'-0" wide landscaped area, exclusive of sidewalks and utility easements, shall be provided between the parking lot and street right of way to accommodate the required screening shrubs.

9.13.5 Design Requirements

Landscape islands shall be created to comply with the above numerical requirements, to provide shade canopy and to break up the visual monotony of large asphalt covered areas. The requirements are as follows:

- Landscaped terminal islands shall be provided at the end of each parking row. Terminal islands shall contain at least one (2) trees and shall be the approximate size of two (2) parking spaces.
- Additional intermediate islands shall be created when the maximum number of parking spaces between terminal islands is greater than twenty (20). (See Figure 9.13.1)
- All landscaped islands shall be a minimum of 250 sq. ft.
- All landscaped islands shall be provided with raised concrete curbs to prevent vehicular intrusion.

9.13.6 Additional Requirements

- No tree shall be planted closer than three (3) feet to a curb.
- All new trees shall have a minimum caliper of 4" at installation.
- All required landscaped areas shall be provided with a permanent and adequate means of irrigation and shall be adequately maintained.
- Each island and screening buffer zone shall be planted with ground cover or sodden lawn in addition to canopy trees.
- Large canopy shade trees are required for terminal islands and must be suitably sized, located and maintained to provide a clear trunk height of seven (7) feet at maturity to allow for unobstructed sight lines. A combination of canopy and ornamental trees that add color and variation may be planted in perimeter areas. Final species selection shall be coordinated with the FP&C Project Manager and Grounds Maintenance representative.
- Where canopy trees are located along the perimeter with screening shrubs, sight lines shall be maintained between the underside of the canopy and the top of the shrubs for security. (See Figure 9.13.2)
- All landscaping shall be arranged so as not to obscure traffic signs or fire hydrants, or obstruct drivers' sight distance within the parking area and at driveway entrances.

- Preserve existing trees where possible, especially native species. All trees that have been designated by the University as existing to remain or existing to be relocated shall be protected and moved according to UH Grounds Maintenance requirements.
- No new parking lot or sidewalk paving or curbs shall encroach within the drip line of existing trees. No equipment, dirt or construction materials shall be stockpiled within the dripline of existing trees.

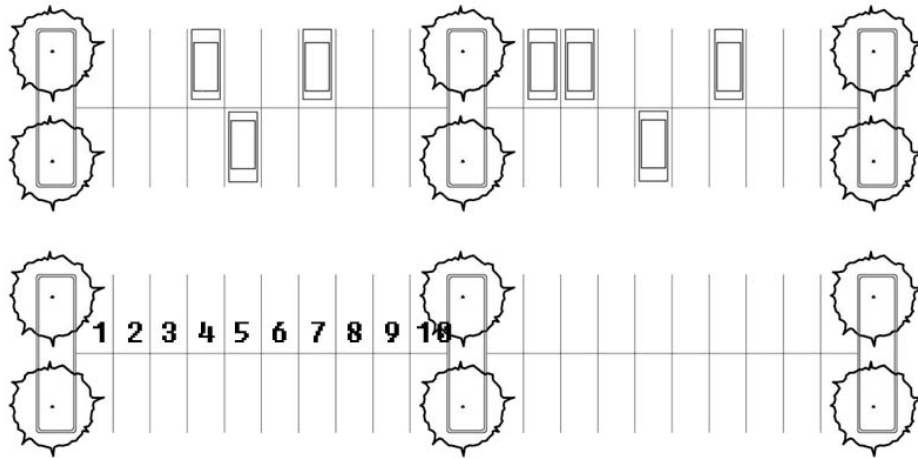

**FIGURE 9.13.1
PARKING**

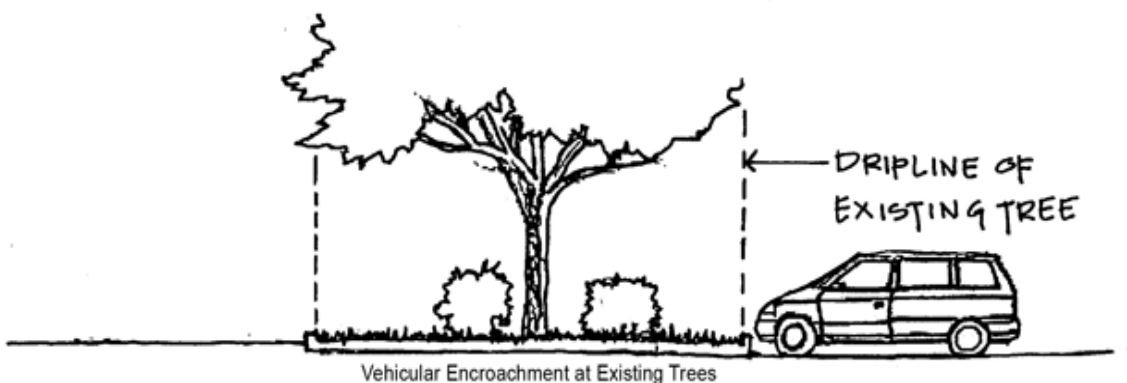
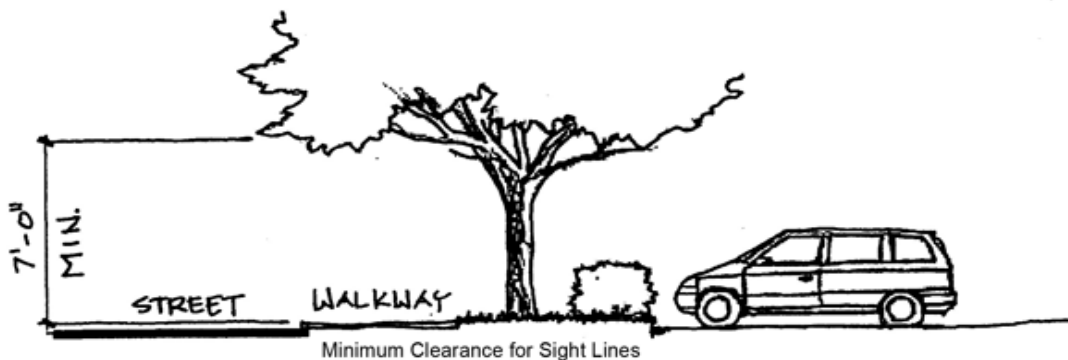

**FIGURE 9.13.2
LANDSCAPING OF PARKING AREAS**

9.14 MAINTENANCE AND REPAIR

9.14.1 Introduction

All pavements require maintenance. They need this attention because stresses producing minor defects are constantly at work. These stresses may be caused by traffic loads, temperature fluctuations, or by changes in moisture content in the soil. Regardless of the cause, the result is the same -- without timely maintenance the pavement ultimately deteriorates. Preventive maintenance means the early detection and repair of minor defects, before major corrective action is necessary; it is the only proper way to care for a parking lot.

9.14.2 Proper Drainage

For the maintenance of parking lots, moisture and drainage have three implications. First, a properly functioning drainage system can eliminate a number of future maintenance problems. Second, surface repair of a pavement defect caused by poor drainage will merely be a temporary solution, since it treats only the symptom, not the cause. Third, the most important repairs are those that will stop water from getting beneath the pavement surface. These repairs can prevent even larger maintenance expenditures in the future.

9.14.3 Inspection and Evaluation

The key to successful maintenance is careful planning and programming of the work to be done. The first step in planning is a periodic evaluation of all parking areas and access roads in the system.

The parking lot should be thoroughly inspected at least twice a year for surface condition, structural strength, and drainage. The inspection should be done on foot rather than from a slow-moving vehicle. This enables the inspector to notice very small cracks and defects. Subtle signs of future trouble, such as mud or water on the pavement, can be detected and recorded.

In all cases of pavement distress, it is important to determine the cause(s) of the difficulty. This will facilitate repairs that will both correct the defect and prevent its recurrence. Time and money spent for such repairs are well invested, since the same repairs will not have to be repeated in the future.

When the inspection has been completed, there should be a record of problem areas, as well as an idea of the general condition of the pavement.

When these inspections reveal minor defects they should be repaired immediately, before they deteriorate into pavement failures requiring major maintenance expenditures.

9.14.4 What to Look For

Pavements in need of maintenance or repair can exhibit any or all of these conditions:

Raveling. This is the progressive separation of aggregate particles in a pavement from the surface downward. Usually, the fine aggregate comes off first and leaves little "pock marks" in the pavement surface. As the process continues, larger and larger particles are broken free, and the

pavement soon has the rough and jagged appearance typical of surface erosion. Raveling can result from lack of compaction during construction, construction during wet or cold weather, dirty or disintegrating aggregate, poor mix design, or extrinsic damage to the pavement.

Alligator Cracks. These are interconnected cracks forming a series of small blocks resembling an alligator's skin or chicken wire. In most cases, alligator cracking is caused by excessive deflection of the surface over unstable sub grade or lower courses of the pavement. The unstable support usually is the result of saturated granular bases or sub grade. The affected areas are usually not large. They can cover entire sections of a pavement, and when this happens, it usually is due to repeated heavy loadings exceeding the strength of the pavement.

Upheaval. Upheaval is the localized upward displacement of a pavement due to swelling of the sub grade or some portion of the pavement structure. Upheaval may also be caused by the swelling effect of moisture on expansive soils.

Pot Holes. These are bowl-shaped holes of various sizes in the pavement, resulting from localized disintegration of the pavement under traffic. Contributory factors can be improper asphalt mix design, insufficient pavement thickness, or poor drainage. Also, potholes may simply be the result of neglecting other types of pavement distress.

Grade Depressions. Depressions are localized low areas of limited size that may or may not be accompanied by cracking. They may be caused by traffic heavier than that for which the pavement was designed, by settlement of the lower pavement layers, or by poor construction methods. A depressed, cracked area frequently denotes a plastic failure in the base or sub grade. A cracked area without permanent deformation often indicates an elastic movement in the pavement structure.

Effects of Tree Roots. This is either an upheaval situation in which the growth of the tree roots pushes the pavement up or a depression due to the trees removing moisture from the soils under the pavement. Treatment of these areas should be coordinated with the Campus Grounds Department.

9.14.5 Corrective Actions

These are some typical cases of pavements requiring maintenance, and the proper methods of correcting the deficiencies.

Pavement in Good Condition. Typically, a pavement in good condition might exhibit fine cracking, and some raveling of the fine aggregate; the ordinary effects of some wear and tear.

The remedy for this condition is the application of a light seal coat, such as a fog seal or an emulsified asphalt slurry seal. For University of Houston Parking lots seal coating shall consist of two coats of coal tar asphalt sealer with eight pounds per gallon of concentrate sand aggregate and 5% latex additive. Seal coat should be allowed to cure for a minimum of 24 hours before re-striping and marking.

All newly paved lots should be seal coated within 12 months of completion and every three years thereafter to maximize the life of the pavement.

Pavement in Fair Condition. Such a pavement is characterized by random cracks of up to 13 mm (1/2 in.) in width, and raveled aggregate. Seal these cracks by:

- If needed, rout out the crack to the sealant manufacturers' specifications for width to depth ratio. Clean the crack using wire brushing, high-pressure air, sandblasting, hot air blasting, or high-pressure water. This is a key step to crack sealing or filling. If the crack is not thoroughly cleaned the sealant will not adhere to the sides. Thoroughly dry the crack before sealing.
- After removing the old sealant and/or cleaning the cracks, check them for depth. Generally if they are over 19mm (3/4 in.) deep a backer rod is used to conserve sealant. The backer rod should be a compressible, non-shrinking, non-absorbent material with a melting point higher than the sealant temperature. The backer rod should be about 25% wider than the crack so it doesn't slip down, or float out after installing the sealant.
- Immediately before applying the sealant, inspect the cracks to ensure they are clean, dry and any backer material is properly installed. If the cracks have been left unsealed for any period of time, clean them out with compressed air before sealing them.
- The sealant should be applied from the bottom to the top of the crack to prevent air bubbles from forming and creating a weak spot in the sealant. Use a sealant kettle that has an injection wand for the best results. To prevent tracking the sealant should be left about 3 to 6 mm (1/8 to 1/4 in.) below the top of the crack. Use a squeegee to remove any excess sealant on the pavement surface.

Pavement in Poor Condition. This pavement may display random cracks, raveled aggregate, depressions, alligator cracks, potholes, and perhaps upheaval. Repairs these areas by:

- First, the areas of local distress -- areas containing alligator cracks, potholes, and upheavals -- should be repaired. This is accomplished by constructing a Full-Depth asphalt patch.
- Following the repair of local distress, cracks should be filled.
- Depressed areas should be restored to the proper cross-section by applying a leveling or wedge course. This is an asphalt layer of variable thickness, specifically intended to eliminate irregularities in the contour of an existing surface prior to an overlay.
- Finally, an asphalt overlay or slurry seal should be applied.

9.15 UNFORESEEN CIRCUMSTANCES

9.15.1 Purpose

This section outlines the appropriate steps to be followed when unforeseen circumstances or condition occur during the construction of parking lots on the University campus. This section is also aimed at providing the appropriate contacts in the various university departments so that the problem is solved in the most efficient way.

9.15.2 Initial Actions

Whenever an unforeseen circumstance is encountered the Contractor should immediately notify the appropriate Project Managers, i.e. the University of Houston Project Manager and the Contractor's Parking Lot Project Manager (if the contractor uncovering the circumstance is a sub-contractor). The decision regarding the solution of the problem rests initially with these Project Managers. These Project Managers, or the personnel assigned by the Project Managers, are responsible for contacting the respective agencies or departments affected by the circumstance. If an unsafe circumstance is encountered, work in the affected area should immediately cease and all non-essential personnel should vacate the immediate area to a safe distance and await a decision by the appropriate agency.

9.15.3 Contacts

Following is a list of contacts for specific items uncovered during construction (numbers as of 7/20/2015):

- For general inquires:

FACILITIES, PLANNING AND CONSTRUCTION (713) 743-8025

- Telephone/telecommunications, fiber optic cables (buried, encased in concrete, etc):

DATA COMMUNICATIONS (713) 743-1111

- Electrical lines or devices:

UTILITY SERVICES (713) 743-5791

- Water, steam or other utility lines:

UTILITY SERVICES (713) 743-5791

- To report a theft or vehicles trespassing on construction sites:

CAMPUS POLICE (713) 743-0600 (non-emergency)

- Sprinkler lines or sprinkler system problems:

GROUNDS DEPARTMENT (713) 743-5745

- General parking and access questions:

PARKING AND TRANSPORTATION (713) 743-1097

- Physical safety questions:

FIRE DEPARTMENT (713) 743-1635

9.16 WORKING WITH CAMPUS STAFF

9.16.1 Purpose

Because of the potential negative impact on faculty and staff due to lot closures, construction traffic, traffic barriers, etc., any contractor engaged in parking lot work for the University of Houston must be prepared to interface and coordinate with the appropriate University departments. This section addresses the principal construction issues and the relevant University departments that need to be contacted in order to resolve issues either in anticipation or as they arise.

9.16.2 Parking Permits

Except for outlying and visitor lots all University of Houston Parking Lots require a permit for parking. Contractor parking is available at ERP with Owner provided bus service at designated times.

UH Department of Parking & Transportation may allow, at its option, a small number of Contractor cars to be parked within a project's construction limits. No other on-campus parking will be provided to or used by Contractor or any of its employees, subcontractors, consultants, agents or representatives.

Permits for the duration of a project may be secured through the Facilities, Planning and Construction Office. Failure to display these permits may result in ticketing or towing. Contractor vehicles shall park in authorized spaces and shall not park on the grass or in other ways to disrupt traffic.

9.16.3 Construction Barriers and Marking

All construction sites should be clearly and adequately marked to prevent non-construction personnel from entering the site without approval. Construction barriers, cones and orange plastic fencing should be used to prevent pedestrians and non-construction vehicles from inadvertently entering the work area. Sub-contractors are responsible for the safety of all personnel entering or leaving the work site.

9.16.4 Lot Closures

Whenever a parking lot must be closed for construction or repairs three to five class days' notice is required. The Parking and Transportation Department will arrange to notify users of the lot being closed. It is imperative that lot closures, especially during normal class times, are kept to an absolute minimum. Since the University also functions as a cultural center these lot closings must be extremely flexible.

9.16.5 Campus Police

If roads or driveways need to be closed for limited periods of time to allow access for heavy equipment, the Campus Police will make arrangements for officers to control and reroute traffic on campus. Campus Police should be given at least three days' notice of these requirements.

9.17 GLOSSARY Industry Glossary such as that at http://www.asphaltinstitute.org/wp-content/uploads/Asphalt_Industry_Glossary_of_Terms3.pdf