



**UNIVERSITY OF HOUSTON
Campus Facilities Planning Committee
Request for Project Approval Form**

1. **Project Number**
2. **Project Name** **Transit Shelters**
3. **Committee Date** **July 9, 2010**
4. **Requesting Department** **Parking & Transportation**
5. **Contact Name & Phone Number** **Bob Browand, x3-5847**
6. **Presenter:** **Bob Browand**
7. **Description of Request**

Background Information:

In February of this year, University Services and the Department of Parking and Transportation solicited proposals from vendors interested in providing bus shelters on the University campus in exchange for advertising revenue.

Upon selection of vendor and design, this item was presented to the Committee in June 2010. At that time, the Committee approved the design but determined that the inclusion of advertising on the shelters was incompatible with academic areas. It was suggested instead that locations near housing and retail areas be considered. This item requests the committee's approval of shelters at six locations near campus residence and student service buildings.

Project Overview:

The selected vendor, MSS Media, has agreed to provide shelter and advertising kiosk designs which complement the visual vocabulary of the campus. The shelters are constructed of "natural metal color" perforated metal panels, tubular steel, and standing seam metal roofing incorporating frosted white polycarbonate panels. Angled side panels and a raked roof correspond to the silver diagonal employed on the new UH signage brand. The use of silver finished metal recalls similarly finished metal on the campus' historic buildings.

The materials are vandal-resistant and long-lasting; the contract with MSS Media obligates the vendor to repair all major damage (breakage resulting from cars, falling branches, or other hazards) and heavy maintenance, and Parking & Transportation to address all minor maintenance issues (dents, scratches, corkboard wear and tear) and cleaning.

Each shelter includes an interior-facing cork bulletin board. A changeable advertising panel is on the exterior face of the board. Two-sided advertising panel kiosks will be located nearby. Several University-based operations (such as Dining Services, GreenUH, Barnes and Noble) have expressed strong interest in renting the advertising space. Advertising of alcoholic beverages, tobacco products, fire arms, or any sexually oriented content will not be allowed.

University Services/P&T propose to install six such shelters in housing and student service areas: one on University Drive near the UC, one at the Campus Recreation & Wellness Center, one at Moody Towers, one at the Quadrangle, one at Bayou Oaks, and one at Calhoun Lofts. If these locations are successful, University Services/P&T will explore purchasing advertising-free kiosks along the shuttle route in academic areas.

Shuttle shelters are a service improvement which shuttle customers have requested. The shelters will clearly identify stops, make traversing the campus easier to understand (by their visibility and incorporated routes and maps), and provide a more comfortable wait for the shuttle.

- | | | |
|------------|-----------------------------|------------------------------|
| 8. | Cost of Project | No cost to University |
| 9. | Source of Funding: | NA |
| 10. | Proposed Start Date: | Upon approval |

Spencer Moore
Executive Director
Facilities Planning & Construction

Date: _____

Attachments



Voting Results:

____ Motion Failed

____ Motion Passed

____ Motion Passed with the Following Modifications:

____ Motion Deferred to a Future Meeting Pending Receipt of Additional Information:



PROPOSED TRANSIT SHELTER RENDERING

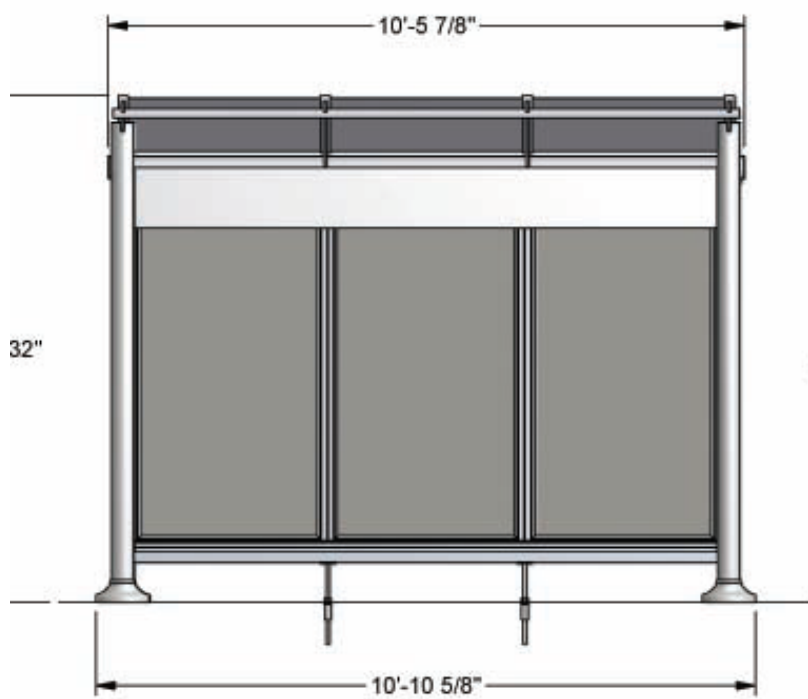

FRONT VIEW

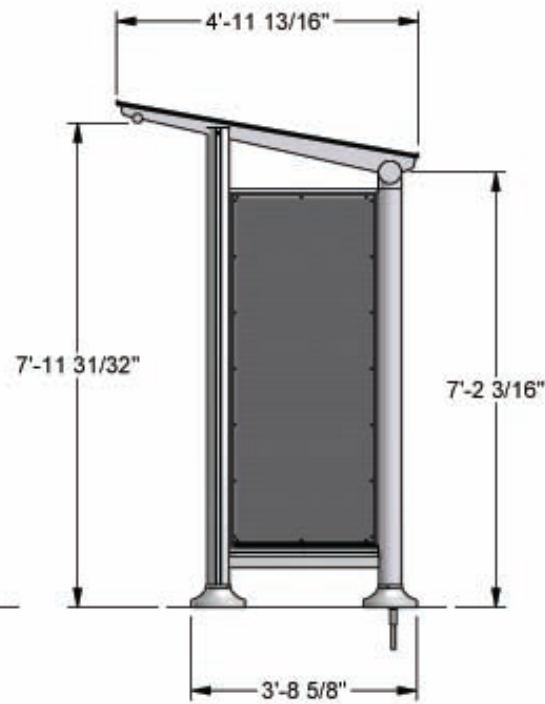

**SIDE VIEW
STANDARD FRONT POST**

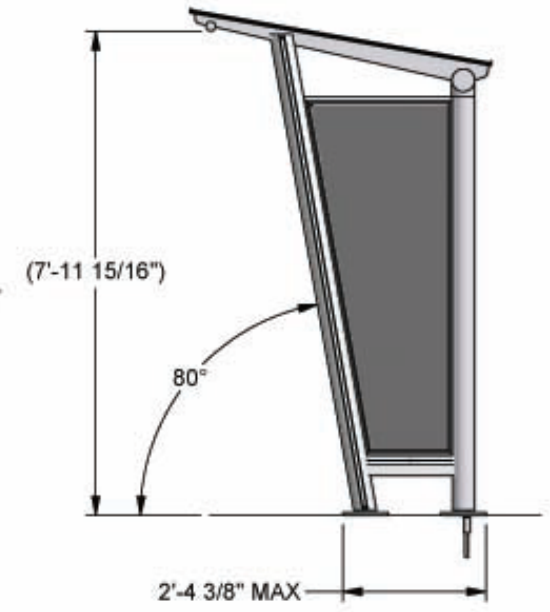

**SIDE VIEW
ANGLED FRONT POST**



PROPOSED TRANSIT SHELTER EXAMPLE INSTALLATION
PROPOSED TRANSIT SHELTER DIMENSTONS



PROPOSED LOCATIONS OF TRANSIT SHELTERS WITH
ADVERTISING PANELS